

LIFTERS

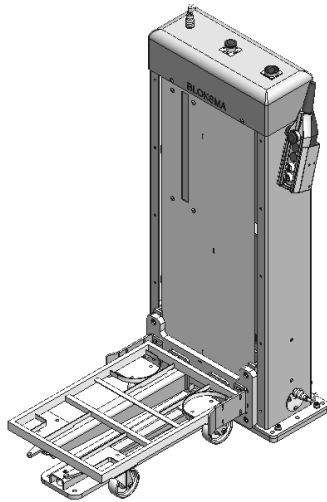

Illustrated version:
stationary lifter

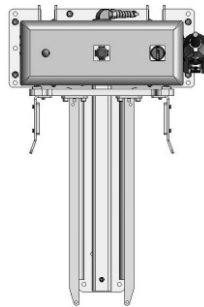

Electric lifter HES-F HET-F HEM-F

Front loading – stationary /
semi-mobile / mobile
trolley loadwise

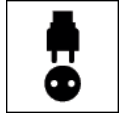

Suitable for Bloksma trolley
BOF + BOZ (see chapter TROLLEYS)

Standard control element
Hand lever on device
(Options see Overview CONTROL ELEMENTS)

Options:
automatic height adjustment,
trolley load control etc.

Difference between
stationary / semi-mobile / mobile
see overview MOBILITY

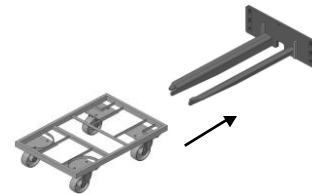

Stationary	Semi-mobile	Mobile	Load capacity	Size of trolley mm	Working height above floor level (GOK)
141109	141029	142570	200 kg	600 x 400	720 mm
141110	141030	142571	200 kg	600 x 400	920 mm
141111	141031	142572	300 kg	600 x 400	720 mm
141112	141032	207992	300 kg	600 x 400	920 mm

141115	141035	142576	500 kg	600 x 400	720 mm
141116	141036	142577	500 kg	600 x 400	920 mm

Stationary	Semi-mobile	Mobile	Load capacity	Size of trolley mm	Working height above floor level (GOK)
141117	141037	142578	200 kg	800 x 600	720 mm
141118	141038	142579	200 kg	800 x 600	920 mm
141119	141039	142580	300 kg	800 x 600	720 mm
141120	141040	142581	300 kg	800 x 600	920 mm

141123	141043	142584	500 kg	800 x 600	720 mm
141124	141044	142585	500 kg	800 x 600	920 mm

Power demand: 230V/50Hz / lifting speed 31 mm/s (47 mm/s on request)

Other models / dimensions / loads / lifting speeds as well as control elements on request.

The appearance of the device may deviate from the plotted models.

LIFTERS

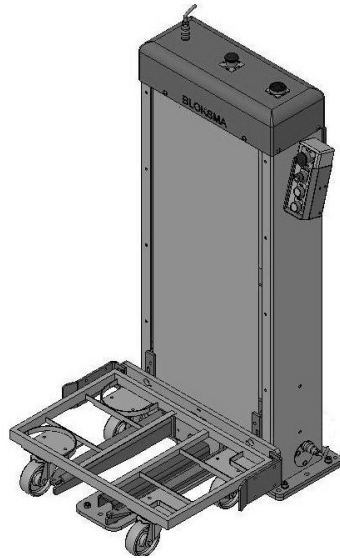

Illustrated version:
stationary lifter

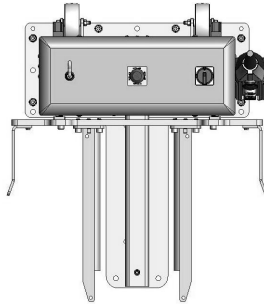

Difference between
stationary / semi-mobile / mobile
see overview MOBILITY

Electric lifter HES-F HET-F HEM-F

Front loading – stationary /
semi-mobile / mobile
trolley crosswise



Suitable for Bloksma trolley
BOF + BOZ (see chapter TROLLEYS)

Standard control element
Hand lever on device
(Options see Overview CONTROL ELEMENTS)

Options:
automatic height adjustment,
trolley load control etc.

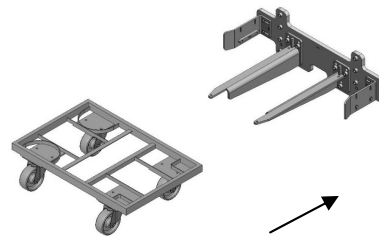

Stationary	Semi-mobile	Mobile	Load capacity	Size of trolley mm	Working height above floor level (GOK)
141125	141045	142555	200 kg	600 x 400	720 mm
141126	141046	142554	200 kg	600 x 400	920 mm
141127	141047	142556	300 kg	600 x 400	720 mm
141128	141048	142557	300 kg	600 x 400	920 mm

141131	141051	142560	500 kg	600 x 400	720 mm
141132	141052	142561	500 kg	600 x 400	920 mm

Stationary	Semi-mobile	Mobile	Load capacity	Size of trolley mm	Working height above floor level (GOK)
141133	141053	142562	200 kg	800 x 600	720 mm
141134	141054	142563	200 kg	800 x 600	920 mm
141135	141055	142564	300 kg	800 x 600	720 mm
141136	141056	142565	300 kg	800 x 600	920 mm

141139	141059	142568	500 kg	800 x 600	720 mm
141140	141060	142569	500 kg	800 x 600	920 mm

Power demand: 230V/50Hz / lifting speed 31 mm/s (47 mm/s on request)

Other models / dimensions / loads / lifting speeds as well as control elements on request.

The appearance of the device may deviate from the plotted models.